

Variety of Performances for many Media Twin Screw Pumps and Systems Series W, V, U and T For Oil & Gas, Industrial and Marine Applications.



B Bornemann
Pumps



Bornemann was established in 1853 and has been designing and constructing pumps and pump systems for over 75 years.

In 1934, Bornemann began designing and manufacturing our Twin Screw Pumps with external bearings, which today are still the foundation of our production and the premier pump in our product line.

Agencies and subsidiaries throughout the world guarantee immediate and professional support in all phases of business from extensive consulting through professional engineering to the installation and reliable maintenance of the installed pump and system. Bornemann is certified under DIN EN ISO 9001.

1853 - 2003: 150 years tradition and innovation.

Multi-Purpose Pumping Solutions for a Variety of Fluids

Bornemann offers a wide range of twin screw pumps with external bearings with its "W", "V", "U" and "T" series. Optimised solutions are found for almost any application, including the fields of:

- Oil production
- Tank terminals, tank transfer
- Petrochemical industry
- Refineries
- Marine
- Offshore production

Application advantages:

- Wide range of applications
- Self-priming
- Pumped capacity proportional to speed
- Compact construction
- Direct drive without speed-reducer possible
- Change of pumping direction - simple
- Pumping elements - simple to replace
- Easy maintenance
- For almost all media and fluids
- High viscosities possible
- Low pulsations
- Low noise level
- Dry running possible
- Constant flow at varying pressures and volumes
- Very good suction performance up to NPSH 1-1.5 m / 3-5 feet
- Engineered 2-piece shaft and screw construction



Method of Operation

While pumping there is no metal-to-metal contact within the pump housing. This allows good pumping performance even with non-lubricating and corrosive and contaminated fluids. Even extended periods of dry-running are possible with the Bornemann Pump Design.

As the pump rotates, the intermeshing of the two screws along with the pump housing form chambers. These chambers fill with the pumped fluid and move it from the suction side of the pump to the higher pressure discharge side of the



pump. The pump is designed to allow for reverse flow by simply changing the shaft direction. The suction becomes the discharge and vice versa, all without any modifications to the pump.

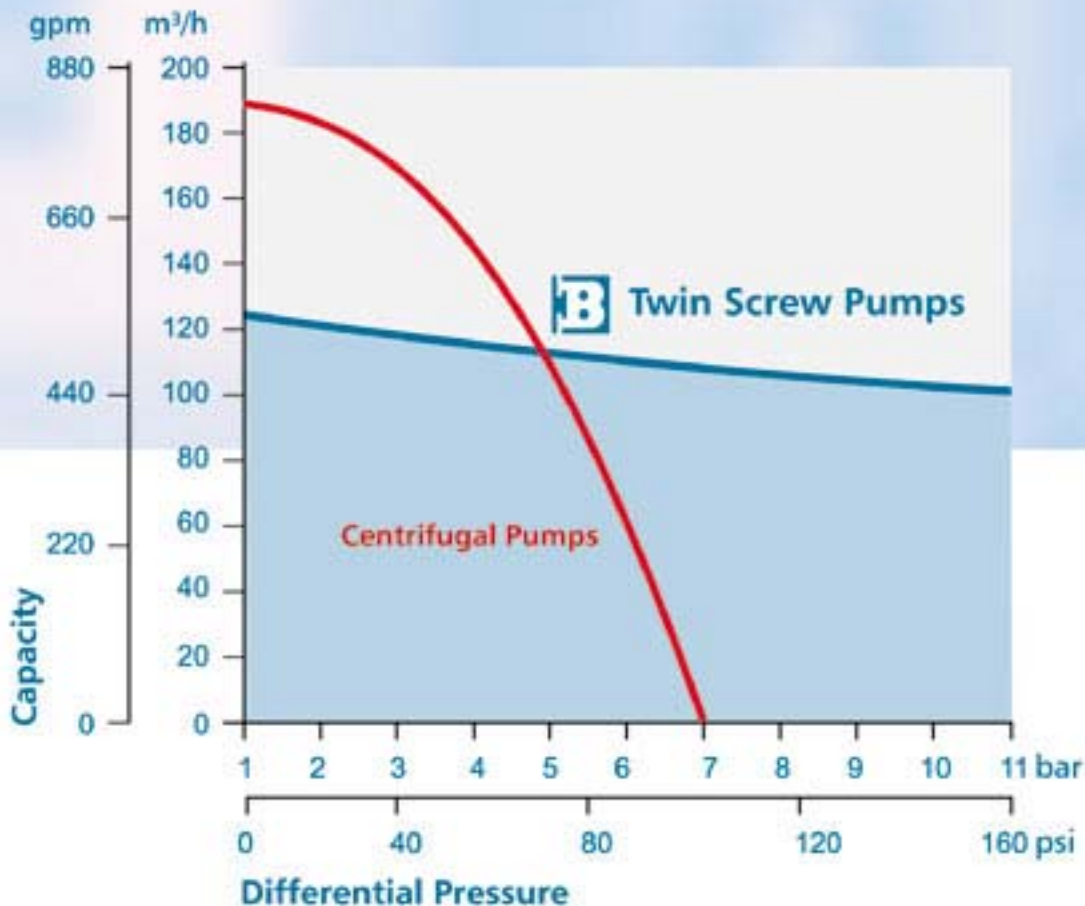



When selecting a pump with a small pitch angle, the back-flow or by-pass flow along the screw tips is extremely negligible. This results in very low NPSH requirements, and very good suction performance and low noise operation.

By varying the pitch of the screws the various pressures and flow rates can be achieved.

Bornemann pump engineered 2-piece screw and shaft design allows for easy change-out of screw pitches. This also allows for a pump design where the shaft and screws are made of different materials. This means the Bornemann Pump to be tailored to your specific pump application.

Bornemann pumps cover a wide range of pressures, flow rates, temperatures, and viscosities to accommodate almost any pumping media requirement. When compared to centrifugal pumps, Bornemann pumps can be applied for almost any fluid application low or high viscosity, non-lubricating, neutral or aggressive, clean or contaminated.

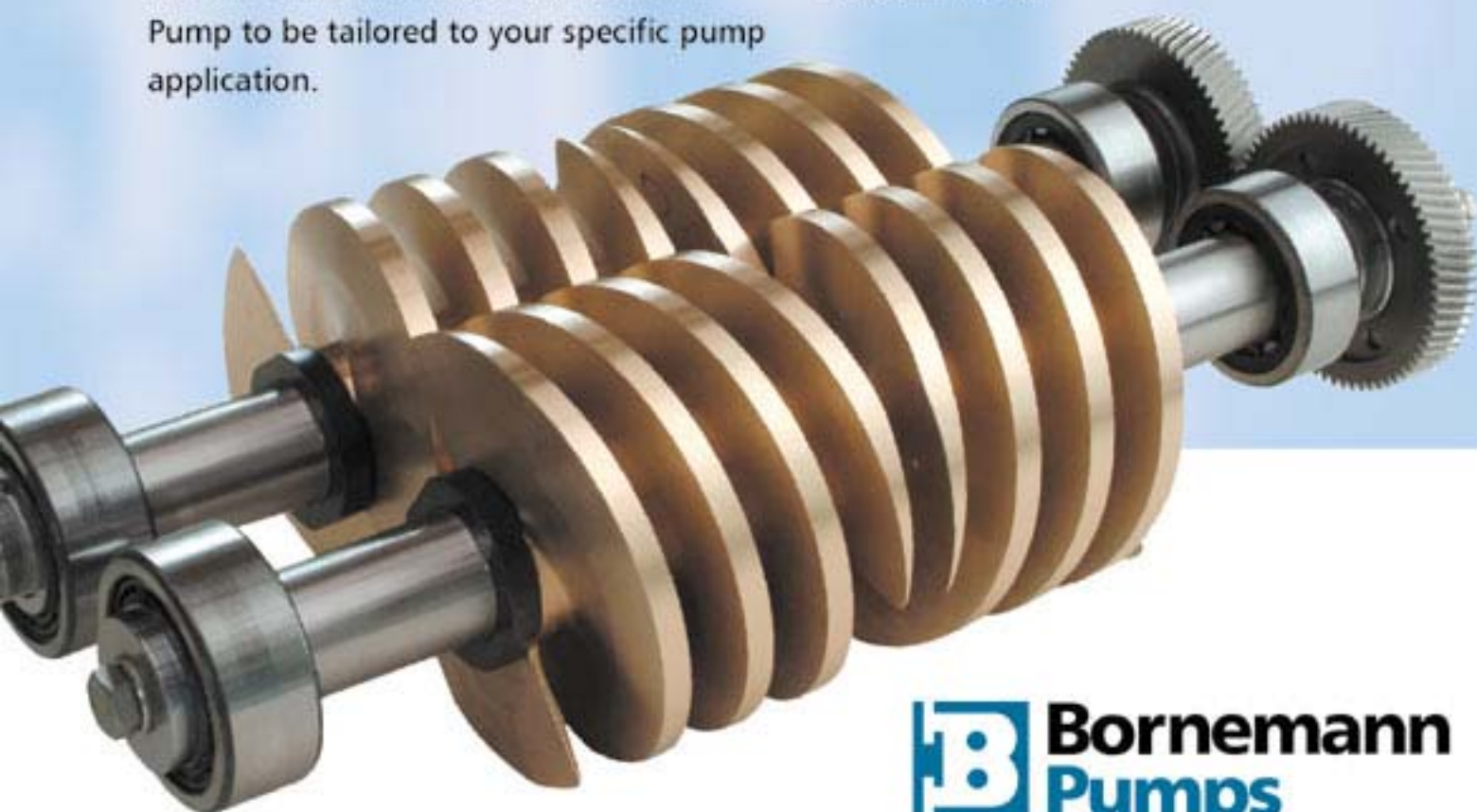

 **Bornemann
Pumps**

Pump Design

- External bearings with no contact to media for long-life even when pumping corrosive or contaminated media
- Large bearing housing with sufficient cooling without external cooling system
- Hardened and precision ground timing gears made of tempered steel
- Can transmit high torque at low noise levels
- Precision setting maintained even after dismantling, no adjusting necessary
- Oil level monitored with sight glass, no dismantling necessary
- Symmetrical housing for changing orientation of suction connection by a simple turn of the housing
- Symmetrical housing design so that flow direction can be easily changed



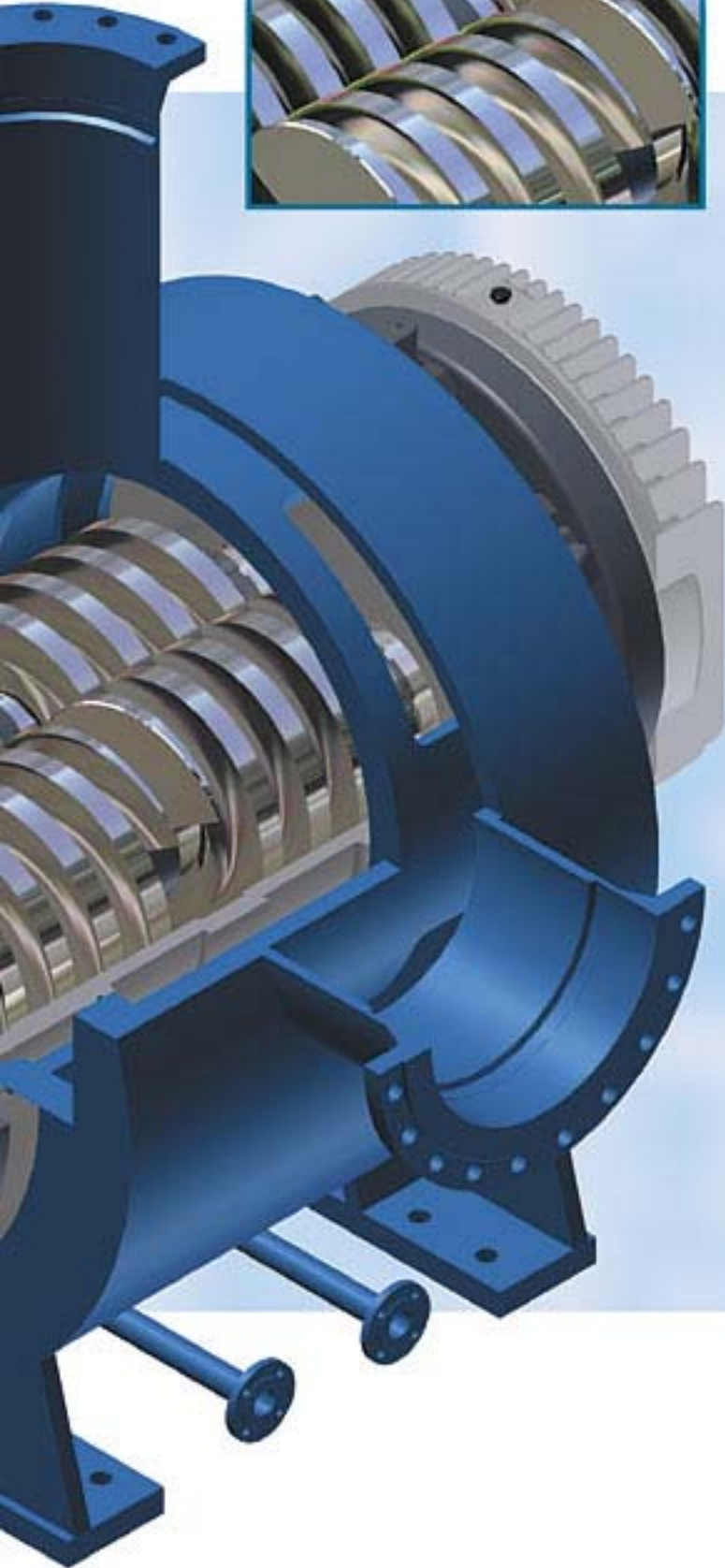

- Optimised mechanical seals to suit the specifics of each application
- Single mechanical seal (reversible) with optional subsequent lip seal for use with flushing fluid
- Double mechanical seal with flushing connection
- Replaceable screws
- Flexible at varying flow rates
- Reversible flow direction without need to change pump internal components
- Wide selection of materials available
- Shaft replacement is made easy because of the 2-piece shaft and screw design
- Built-in recirculation
- Protected against overpressure
- External safety not required
- Pump design protects against mechanical jamming due to air and steam penetration
- Vapour locking does not occur because of constant presence of liquid
- Pump screws always immersed in pumped fluid because suction connections positioned above the center of the conveyor screw
- Cooling and lubrication ensured when used in stripping applications.
- Replaceable housing liner/inserts
- Replaceable liner reduces down-time and is possible without removing pump from piping

Series

Series W

Series W pumps are horizontal twin screw pumps with external bearings. In this design, the bearings do not come into contact with the media. The short model (W zk) is used for applications with high differential pressures.

The rotating faces of the mechanical seals are in the pumping flow (not dead-end). This ensures proper cooling and lubrication. The mechanical seals are on the suction side of the pump and therefore only see suction pressure, never the full higher discharge pressure. In the long model (W z), almost any seal design is possible.

A further advantage of this longer design is that it can pump fluids at higher temperatures up to 350 °C / 660 °F. For the pumping of clean and lubricating media (e. g. lubricating oils), the pumps are available in zi-design, with internal bearings.

Series W



Series V

The pump principle is also available for vertical arrangement the so-called "inline design". In this model the suction and discharge connections are arranged in-line, horizontally. As a result of the symmetric design, the suction and discharge are interchangeable. This series is ideal for use in constricted areas. It is installed on a pump socket. The vertical motors are coupled directly to the pumps - without gears.

Series V



Pump Code

W 3. 2 zk 94

- Pitch in mm
- Bearing design
 - zk= centered short design
 - z= centered long design
 - zi= centered design with internal bearings
- Material index
- Sizes (3-10)
- Twin Screw Pumps
 - W= horizontal
 - V= vertical
 - U= immersed pump with internal bearings
 - T= submerged

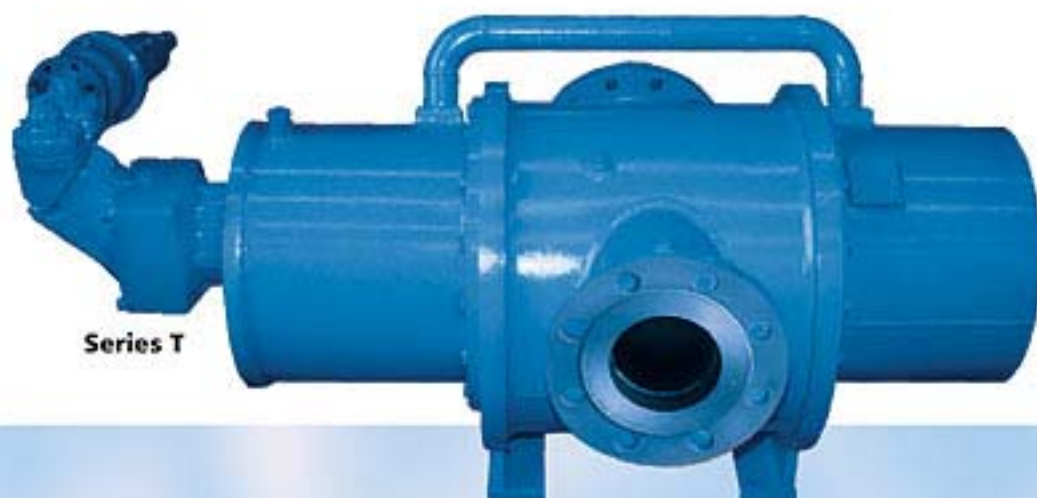

Series T

Series U

This pump is selected where the pump needs to be installed inside the storage tank. The pump and its screws and bearings are immersed and lubricated by the pumped fluid. This series may only be used for clean lubricant oil. Immersions of up to 7 m / 23 ft are possible. Pressure connections and the drive motor are installed on the mounting flange of the tank.

Series T

Vertical submerged pump. The pump is installed directly within the tank or container where the fluid is stored. Hydraulic motors are normally used and directly connected to the pump. The pump and motor are installed and submerged in the tank and fluid.

| external bearings | | internal bearings | | | | DIN / ASTM | | | |
|-------------------|--------|-------------------|------|------|------|---------------------|---------------|---------------|---------------|
| W.z(k) | V.z(k) | W.zi | V.zi | U.zi | T.zi | casing | liner | *shafts | screws |
| X | X | X | X | X | | GG-25 / A48 | | 1.4542 / A564 | GG-25 / A48 |
| X | X | | X | | | GGG-40 / A536 | | 1.4542 / A564 | GG-25 / A48 |
| X | X | | | | | GS-45 / A2765-35 | | 1.4542 / A564 | GG-25 / A48 |
| X | X | | | | | GG-25 / A48 | | 1.4542 / A564 | 1.4057 / A276 |
| X | X | | | | | GG-25 / A48 | | 1.4542 / A564 | 2.1090 / B144 |
| X | X | | | | | GG-25 / A48 | | 1.4542 / A564 | 1.4542 / A564 |
| X | X | | | | | 2.1052 | | 1.4542 / A564 | 2.1090 / B144 |
| X | X | | | | | 2.1052 | | 1.4542 / A564 | 1.4057 / A276 |
| X | X | | | | | 1.4408 / A351, A743 | | 1.4542 / A564 | 1.4542 / A564 |
| X | X | | | | | welded steel | GG-25 / A48 | 1.4542 / A564 | GG-25 / A48 |
| X | X | | | | | welded steel | Ni-Resist | 1.4542 / A564 | GG-25 / A48 |
| X | X | | | | | welded steel | 1.4408 / A351 | 1.4542 / A564 | GG-25 / A48 |
| X | X | | | | | welded steel | GG-25 / A48 | 1.4542 / A564 | 1.4057 / A276 |
| X | X | | | | X | welded steel | Ni-Resist | 1.4542 / A564 | 2.1090 / B144 |
| X | X | | | | | welded steel | 1.4408 / A351 | 1.4542 / A564 | 1.4057 / A276 |
| X | X | | | | | welded steel | 1.4408 / A351 | 1.4542 / A564 | 2.1090 / B144 |
| X | X | | | | | 1.4571 / A182 | 1.4408 / A351 | 1.4542 / A564 | 1.4542 / A564 |
| X | X | | | | | 1.4462 / A789 | 1.4462 / A789 | 1.4542 / A564 | 1.4462 / A789 |

*shaft material zi= 1.7225 / A322

Series U

Performance

| | |
|------------------------|---|
| Capacity: | up to 2700 m ³ /h (12000 gpm) |
| Differential Pressure: | up to 50 bar (730 psi) |
| Viscosity: | 0,5 up to 200000 mm ² /s (cSt) |
| Speed: | max. 3600 min ⁻¹ (rpm) |
| Temperature: | up to 300 °C (570 °F) |

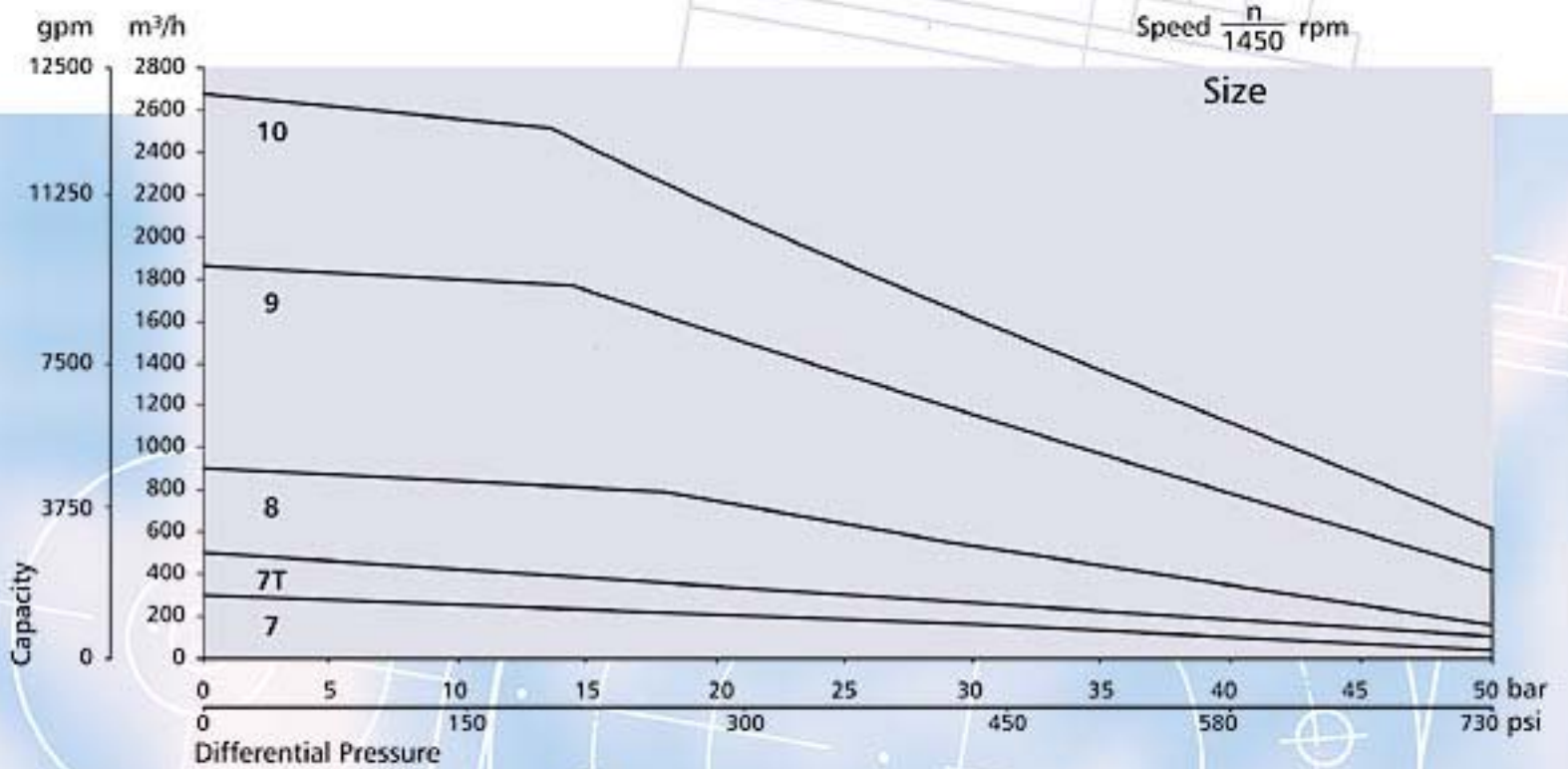

| | |
|------------------------|---|
| Capacity: | up to 150 m ³ /h (660 gpm) |
| Differential Pressure: | up to 35 bar (500 psi) |
| Viscosity: | 0,5 up to 200000 mm ² /s (cSt) |
| Speed: | max. 3600 min ⁻¹ (rpm) |
| Temperature: | up to 300 °C (570 °F) |

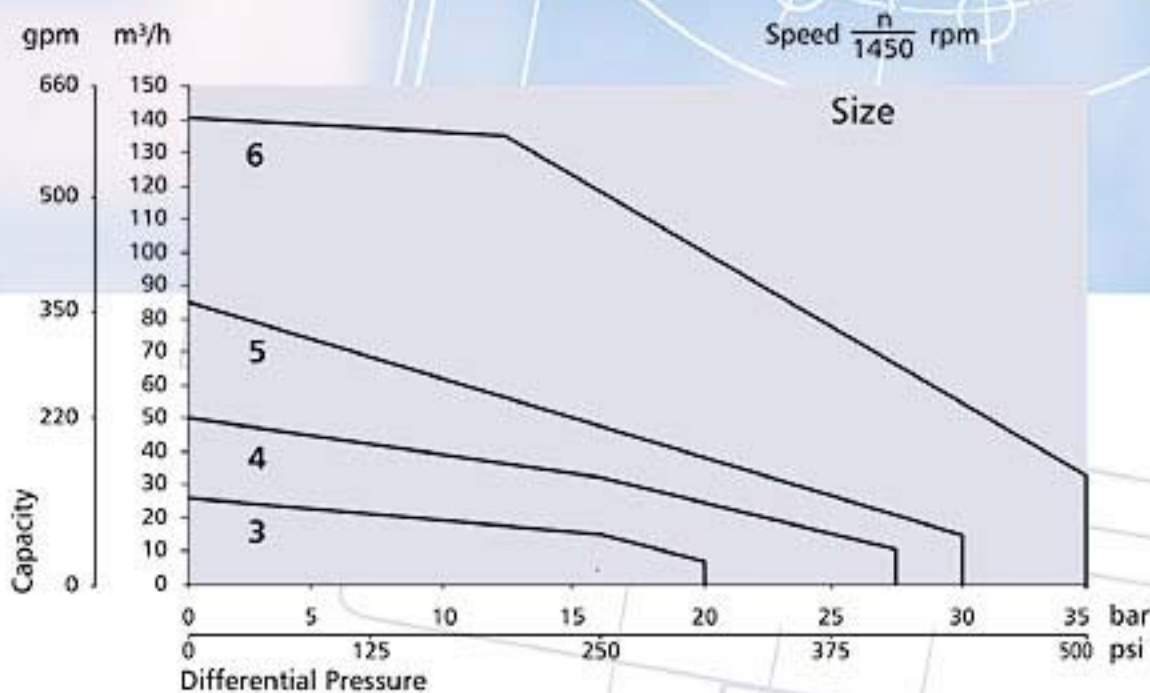

Pump Heating Options

To ensure proper heating of pumped fluids, Bornemann pumps can be constructed with the options below:

- Fully heating jacket or electrically traced heating with insulation available for the fabricated execution.

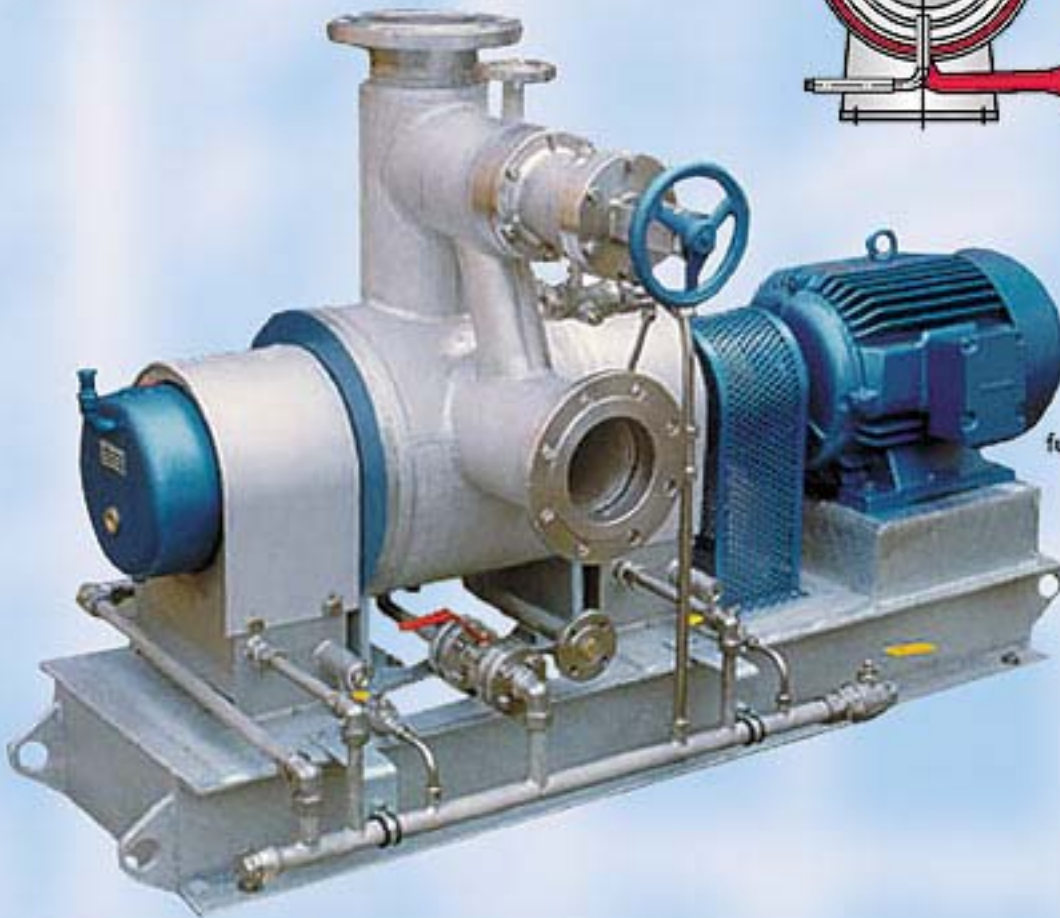
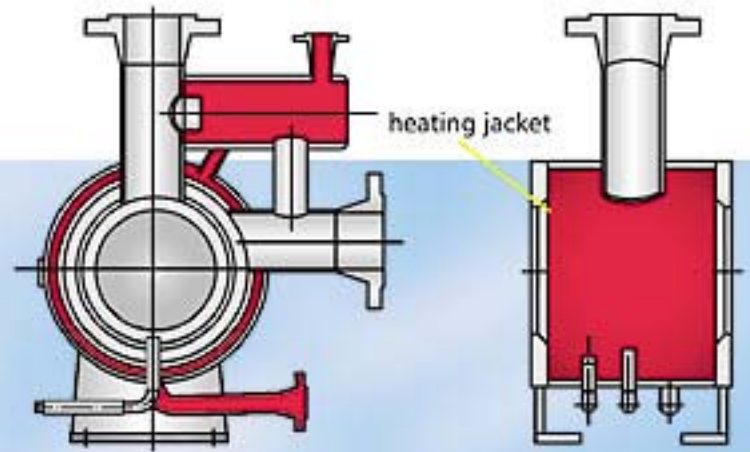

full heating jacket

- Heating foot, coil for thermal oil / steam or electrical trace heating with insulation available for the cast execution.



heating coil / foot

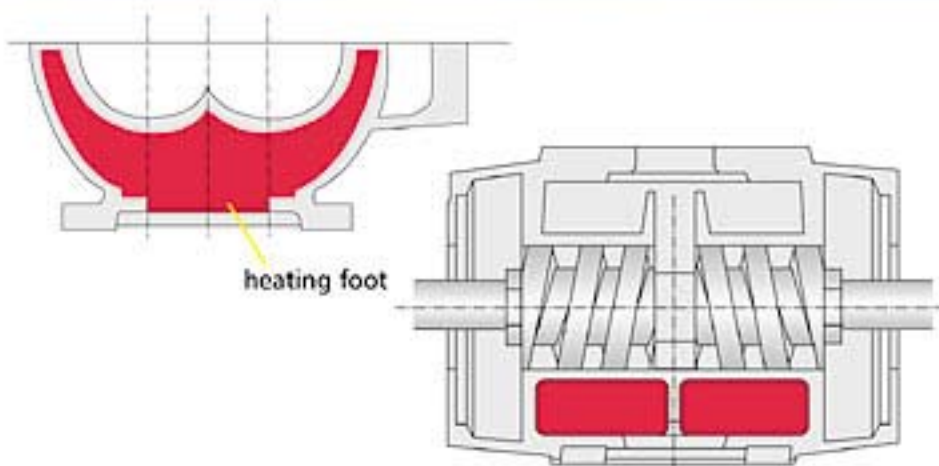

heating foot



electrical trace heating

Reliable Performance, Day after Day, throughout the World.

Bornemann twin screw pumps prove their worth in pumping applications of all kinds throughout the world, which must perform under extreme environmental conditions. Their advantages are operational safety, reliability, and consistent performance, long life and low operating costs.

Oil Production

Bornemann twin screw pumps as transfer pumps are excellently suited to pump mixtures of crude oil, gas, waste and fine particles. They can be used both on and offshore. The ability for the pump to run dry safely allows for the inclusion of gas in the pumped streams. The short bearing design and small screw pitch make it possible to generate high pressures for pipeline applications.

Product applications: crude oil containing gas and water, very heavy crude oil ...

Tank Terminals

Bornemann has a large worldwide installed base of pumps in tank terminals. They can be used wherever a large suction capacity is required. Bornemann Pumps can be found for loading and unloading of ships, tank wagons, tanker trucks as well as storage tanks and pipelines everyday of the year. They perform these duties under challenging conditions including high viscosities and pressures.

Product applications: low to very high-viscosity oil products such as bitumen, tar, chemicals, light and heavy fuel oil, crude oil, mazut ...

Petrochemical Industry /Refineries

Bornemann twin screw pumps are the ideal solution for transfer within terminals where both low and high viscosity products have to be moved or metered. All fluids whether neutral, alkaline or acid and aggressive, abrasive or gaseous are sucked up safely, dosed and pumped.

Product applications: mazut, bitumen, tar, heavy fuel.

Marine and Shipbuilding Offshore.

Bornemann pumps are excellently suited as loading and unloading pumps. Their proven advantage is the easy transfer of fluids with various viscosities such as heating oil, and storage water.

Chemical Industry

Bornemann pumps offer convincing advantages where chemicals are concerned. Because there is no contact between the moving parts in the fluid stream, it is possible to make fluid contacting parts from stainless steel. The result: non-lubricating, corrosive, low viscosity and high viscosity fluids can be conveyed. Bornemann pumps are particularly well suited for shear sensitive, viscous fluids that have to be pumped and handled with care.

Product applications: polymers, liquids sulphur ...



Tank Terminal

| | |
|--------------|--|
| Country: | U.A.E. |
| Pump type: | W9 |
| Medium: | Fuel oil, 55 °C / 130 °F, 380 mm ² /s |
| Capacity: | 120 - 1400 m ³ /h / 530 - 6200 gpm |
| Pressure: | 10 bar / 145 psi |
| Speed: | 200 - 1470 rpm |
| Shaft power: | 95 - 630 kW / 75 - 500 HP |



Refinery

| | |
|--------------|---|
| Country: | Germany |
| Pump type: | W7T |
| Medium: | Molasses, 220 - 250 °C / 430 - 480 °F, 350 mm ² /s |
| Capacity: | 110 - 240 - 370 m ³ /h / 480 - 1060 - 1600 gpm |
| Pressure: | 11 bar / 160 psi |
| Speed: | 600 - 1200 - 1800 rpm |
| Shaft power: | 190 kW / 150 HP |



Offshore

| | |
|--------------|---|
| Country: | Norway |
| Pump type: | W6 |
| Medium: | Produced water, 2 - 70 °C / 35 - 160 °F, 0,4 - 1,7 mm ² /s |
| Capacity: | 21 m ³ /h / 95 gpm |
| Pressure: | 3 bar / 45 psi |
| Speed: | 1400 rpm |
| Shaft power: | 7 kW / 5 HP |



Marine

| | |
|--------------|---|
| Country: | China |
| Medium: | Crude Oil, 85 °C / 185 °F, 130 mm ² /s |
| Capacity: | 210 m ³ /h / 950 gpm |
| Pressure: | 8 bar / 120 psi |
| Speed: | 1450 rpm |
| Shaft power: | 70 kW / 50 HP |



Oil Production

| | |
|--------------|--|
| Country: | Oman |
| Pump type: | W9 |
| Medium: | Crude Oil, 25 - 45 °C / 80 - 120 °F, 900 - 4000 mm ² /s |
| Capacity: | 354 m ³ /h / 1600 gpm |
| Pressure: | 12 - 15 bar / 180 - 220 psi |
| Speed: | frequency converter |
| Shaft power: | 410 kW / 300 HP |



Chemical Industry

| | |
|--------------|---|
| Country: | Germany |
| Pump type: | W7 |
| Medium: | Water, solvent, silicon acrylate, polyether, 20 - 130 °C / 70 - 270 °F, 1 - 15000 mm ² /s |
| Capacity: | 4 - 100 m ³ /h / 18 - 440 gpm |
| Pressure: | 14 - 73 psi |
| Speed: | 300 - 1400 rpm |
| Shaft power: | 55 kW / 74 HP |



Pumps and Systems for Industry,
Environmental and Shipbuilding

www.bornemann.com

Joh. Heinr. Bornemann GmbH
Postfach 1162
31676 Obernkirchen
Germany
Fon +49 5724 390-0
Fax +49 5724 390290
info@bornemann.com



Good communication with our customers is an important feature in Bornemann's Quality Program, from initial project consultation to maintenance. Professional support and fast service are top priorities. Specialists in pumps and systems located in our company headquarters and in nearly 100 representatives

and agencies through the world provide professional quality support on a local level. Our employees and representatives are trained at our training center in order to stay current on new technologies and provide the best support available to our customers.

USA:

Bornemann Pumps Inc.
P.O. Box 1769
Matthews, NC 28106
USA

Fon:
+1 704 849-8636
Fax:
+1 704 849-8637
info.usa@bornemann.com

Argentina:

Bombas
Bornemann S.R.L.
Armenia 2898
B1605CDP Munro
Prov. Buenos Aires
Argentina

Fon:
+54 11 4756-8008
Fax:
+54 11 4756-5541
info.ar@bornemann.com

China:

Bornemann Pumps China
International Trade
Plaza Tianjin
Room 1008 B
No. 129 Nanjing Road
Heping District
TIANJIN

Fon:
+86 22 27126418
Fax:
+86 22 27126419
info.cn@bornemann.com

Singapore:

Bornemann Pumps
Asia Pte. Ltd.
25 Intern. Business Park
German Centre, # 04-08
Singapore 609916
Singapore

Fon:
+65 6 561 6782
Fax:
+65 6 561 6784
info.sg@bornemann.com